

# DeLaval Cooling Systems

A fresh approach  
to milk cooling

 DeLaval

IT ALL REVOLVES  
AROUND YOU

 DeLaval



# Keeping the world's milk fresh

We don't create cooling systems for a range of liquids and sell some of them for milk.

We create solutions specifically for the challenges of cooling, storing and protecting milk.

We believe that keeping milk fresh has some unique challenges that demand a no compromises approach.

We understand that, for you, protecting your income is about protecting your milk, and to do that you must keep it fresh at all times. That's why, at DeLaval, we develop solutions for cooling milk - because when you live milk, you are passionate about keeping it fresh.

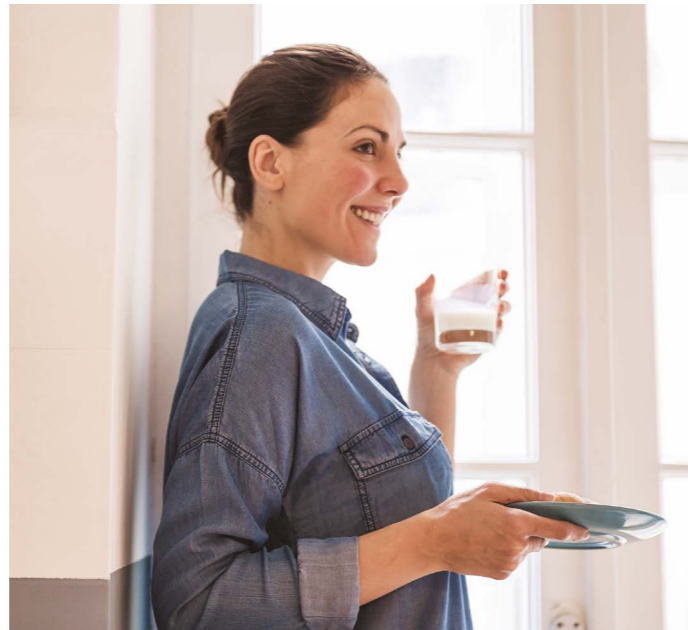

## Beyond cooling

Our drive to help you deliver the highest quality milk goes above and beyond the equipment required to cool, store and protect your precious income. Beyond cooling, we have developed our technology with operating costs, energy savings and the environment in mind, creating solutions that allow you to save money and improve your bottom line whilst reducing your carbon footprint and protecting the environment for future generations.

We also know how important it is to know exactly what's going on with your system, and to react quickly when something goes wrong. That's why we offer the tools to remotely monitor your cooling operation, no matter where you are in the world, and include a service and maintenance agreement for the peace of mind that comes from knowing your milk is always in safe hands.

## Why is it better

At DeLaval we design and manufacture a complete set of solutions for cooling, storing, transporting and protecting your milk. Designed to work together or as individual units, we have a solution to preserve the freshness of your milk through every step of the cooling process - from the moment it leaves the teat, to its collection by the milk tanker.

Low running cost

Service & maintenance is included

50% less refrigerant\*

Remotely monitor your cooling tank

Cool to 4 degrees in 4 seconds\*\*

100% Stainless steel cooling tanks

DeLaval

DeLaval

\*Based on AFCC compared with standard cooling unit

\*\*Based on CWC



# DeLaval complete milk cooling system

DeLaval cooling solutions are versatile and can be used with milking robots, conventional parlours and rotaries. Combine a DeLaval Milk Storage Tank with a Plate Heat Exchanger, Compact Water Chiller and Heat Recovery Tank to complete the ultimate efficient DeLaval cooling system.

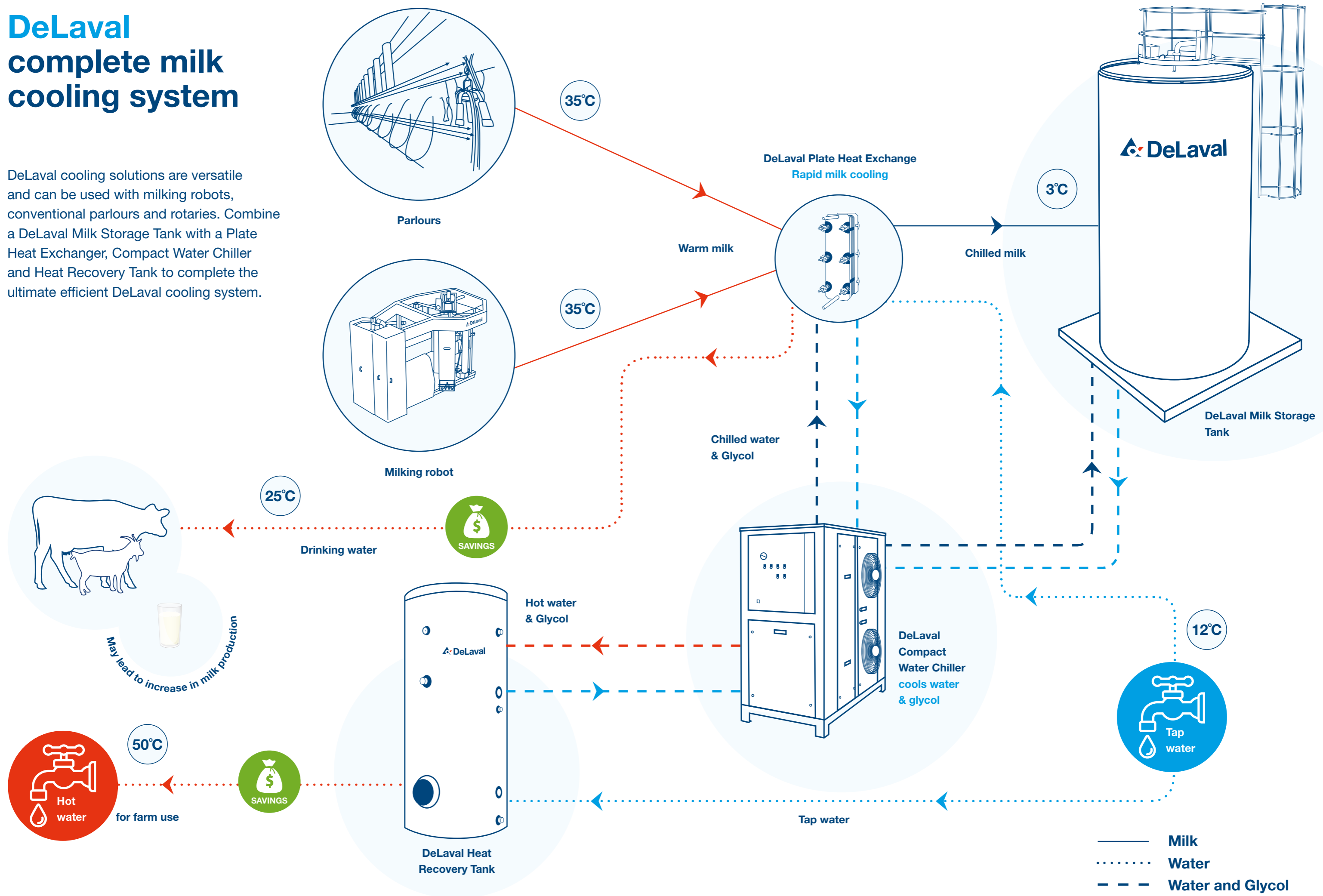

## Faster means fresher

As soon as it leaves the udder, naturally occurring bacteria in the milk start multiplying immediately. In just two hours 1,000 bacteria can increase to 64,000. The faster you cool the milk, the more you slow this process down and the fresher your milk will be. That's why our unique range of chillers are the fastest we've ever developed.



DXCEM with T200

## CMS & AMS Cooling

Our best solution for the in-line cooling of small to very large milk flows, our patented compact coolers are designed to meet your highest demands and deliver in all conditions. Intelligent cooling and temperature control helps to ensure the freshness of your milk before it enters the cooling tank, and precise power control means it only uses the energy necessary to keep your milk fresh, no more, no less. DeLaval CWC can help you to reduce energy costs and improve your bottom line.



## AMS Cooling

The cooling of small milk flows presents a unique set of challenges. Milk flows that vary in volume and milk flows from modern automatic milking systems require a solution that can adjust cooling capacity to match. Our unique and patented AFCC system can handle it all.

With DeLaval Adaptive Flow Controlled Cooling (AFCC), cooling capacity is automatically adjusted to suit milk flow, so varying volumes of milk can be cooled quickly and consistently, without stirring and without the risk of freezing.



DeLaval milk pump FMP

Model	Max Flow	Max Head
FMP55 0.55kW	4m <sup>3</sup> /h	12m
FMP110 1.1kW	13m <sup>3</sup> /h	15m
FMP220 2.2kW	33m <sup>3</sup> /h	25m

## DeLaval Plate Heat Exchangers

### Your cost-saving investment

Pre-cooling reduces the cooling load and thus the energy required. Associated costs, are also reduced. A correctly sized DeLaval plate heat exchanger package can save you up to 60 percent of your refrigeration energy costs.

Stainless Frame Heat Exchanger - Available on request.

Model	M6 Range	BM Range
Minimum Flow (l/h)	3000	1000
Maximum Flow (l/h)	16000	5000
Design Pressure (bar)	10	4
Frame (Painted)	Mild Steel	Aluminium
Plates	SS316	SS316



### Did you know

**Plate heat exchangers**  
2:1 water to milk ratio is only a guide. Lower water ratio can be used to maximising your pre-cooling water availability. At DeLaval, we can design the heat exchanger and cooling system according to your individual needs.

## DeLaval Smooth Operator

### Milk flow stabilization

Smooth operator is a flow control system with level of milk in end unit (or balance tank) as input and speed of milk pump as output.

Level probe is fitted to the container and inverter is connected to milk pump.



When level of milk is between probes of the sensor smooth operator sets speed of pump to medium (adjustable). When high level is reached or during cleaning full speed is used



DXCEM with T300



# DeLaval compact water chiller range

## CWC15-A, CWC30-A, CWC60-A, CWC90-A, CWC120-A

### DeLaval Cooling Performance

Cooling is a major part of our assortment and our chillers have been serving farmers over the past few years in helping cool milk instantly, maintaining its freshness and quality.

### It's all about saving you money!

DeLaval compact water chillers are designed with energy efficient scroll compressors, electronic controlled fans, built in heat recovery and more.

### Your production in mind

At DeLaval, we know milk cooling cannot stop. With this in mind, we designed our chillers to have

- An additional pump for peace of mind
- Two compressor to have 50% capacity if one fails

### New features and benefits

#### Glycol Detection

- Added Safety
- High Level Alarm
- Low Level Alarm

#### Remote Access

- Easy troubleshooting
- Live monitoring
- Data Logging

#### Built in Heat Recovery

- Free warm water
- Reduces energy cost

### Core benefits

- Possibility to cool milk on farms where traditional in-tank cooling is not enough
- Provides fastest cooling rate of all cooling system types → conserves milk quality
- One-piece design makes it easy to install and maintain
- Possible to install outside the building to conserve space
- Built in heat recovery to limit energy use
- Makes possible use of vertical tanks with limited cooling surface to store the milk
- Designed with long working time in mind, double system to minimize risk of total failure
- Multiple compressors circuits to adjust capacity to actual milk flow on farm

### Did you know

DeLaval CWC-A chillers have pump backup to give you a peace of mind for protection from failure.



### ▼ DeLaval Compact Water Chiller CWC15-A



Model	CWC15-A / 3 x 400V 50Hz
Capacity at 38°C	15 kW
Milk Flow, ΔT 6°C*	1800 l/h
Milk Flow, ΔT 8°C*	1400 l/h
Milk Flow, ΔT 10°C*	1000 l/h
Weight	425 kg
Length	1.95 m
Width	1.24 m
Height	1.14 m
Refrigerant	R410A
Nominal Current	34 Amps
Running Current*	14 Amps

\*Estimate Only

### ▼ DeLaval Compact Water Chiller CWC30-A



#### Unique TWIN Circuit capacity

Our CWC30-A have the capability to have two separate 15kW circuits. This allows you to have two deep cooling circuit, maximising performance and energy consumption.

Model	CWC30-A / 3 x 400V 50Hz
Capacity at 38°C	30 kW
Milk Flow, ΔT 6°C*	3600 l/h
Milk Flow, ΔT 8°C*	2700 l/h
Milk Flow, ΔT 10°C*	2200 l/h
Weight	700 kg
Length	1.95 m
Width	1.24 m
Height	2.20 m
Refrigerant	R410A
Nominal Current	43 Amps
Running Current*	24 Amps

\*Estimate Only

### ▼ DeLaval Compact Water Chiller CWC90-A



Model	CWC90-A / 3 x 400V 50Hz
Capacity at 38°C	90 kW
Milk Flow, ΔT 6°C*	11000 l/h
Milk Flow, ΔT 8°C*	8100 l/h
Milk Flow, ΔT 10°C*	6500 l/h
Weight	1500 kg
Length	3.0 m
Width	2.2 m
Height	2.0 m
Refrigerant	R410A
Nominal Current	135 Amps
Running Current*	92 Amps

\*Estimate Only

### ▼ DeLaval Compact Water Chiller CWC60-A



Model	CWC60-A / 3 x 400V 50Hz
Capacity at 38°C	60 kW
Milk Flow, ΔT 6°C*	7200 l/h
Milk Flow, ΔT 8°C*	5400 l/h
Milk Flow, ΔT 10°C*	4300 l/h
Weight	900 kg
Length	3 m
Width	1.7 m
Height	2.0 m
Refrigerant	R410A
Nominal Current	77 Amps
Running Current*	55 Amps

\*Estimate Only

### ▼ DeLaval Compact Water Chiller CWC120-A



Model	CWC120-A / 3 x 400V 50Hz
Capacity at 38°C	120 kW
Milk Flow, ΔT 6°C*	14000 l/h
Milk Flow, ΔT 8°C*	11000 l/h
Milk Flow, ΔT 10°C*	8600 l/h
Weight	1680 kg
Length	3.0 m
Width	2.2 m
Height	2.0 m
Refrigerant	R410A
Nominal Current	160 Amps
Running Current*	116 Amps

\*Estimate Only

# DeLaval tank range

## Milk cooling and storage at its best



### Safeguard your milk quality from teat to tank.

At DeLaval, we know the importance of safeguarding milk quality once it has left the cows teats. To ensure your milk retains its quality, DeLaval has developed a premium performance range of cooling tanks – protecting your most valuable asset.

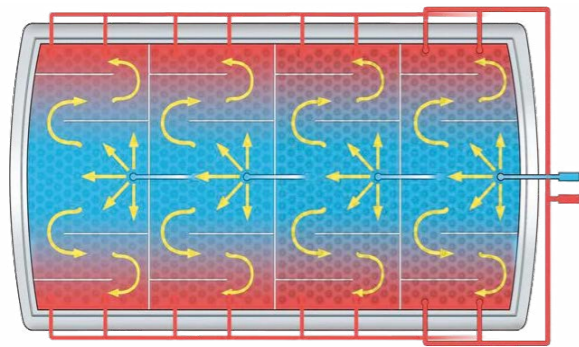

High gas turbulence inside our evaporators gives rapid cooling and saves energy costs



#### Did you know

DeLaval Tank insulation is never less than

50mm on tank walls

#### How is this manufactured?

The polyurethane coating process is controlled by an infrared camera to achieve highly even insulation.

#### Your Benefits – Lower Running Costs

- Best thermal protection
- Prolong lifetime of compressor
- Milk kept cooled with no electricity
- Reduction in energy cost



### ► DeLaval Heat Recovery Storage Vessel ERS

DeLaval heat recovery system ERS can produce 0.7 litres of warm water (53°C) from every litre of warm milk (35°C).

- Reduce energy cost
- Reduce cooling time
- Resistant against hard water



Picture shows DXCE with T200



### ◀ DeLaval Closed Tank Assortment

Initiates, controls and checks the tank cleaning and milk cooling, providing farmers comfort, safety and quality control.

#### Cleaning Unit T200

- Direct to drain or circulation cleaning
- Short cleaning cycle
- Reduction in hot and cold water

#### Cleaning Unit T300

- Direct to drain principle
- Short cleaning cycle
- Reduction in hot and cold water
- Mobile SMS Ready



#### Optimised cleaning through rotating nozzle

The cleaning of the tank is a key aspect of the cooling ensuring top quality milk, over and over again.

To get to all the corners and complete the entire inner surface, DeLaval has integrated the cleaning nozzle in the rotating blades, ensuring a complete and thorough cleaning of the inside of the tank.

### ◀ DeLaval DX3S Milk Tank

#### Advance Agitator Design

Milk splashing at low volume and foaming can damage milk quality.

#### Gentle Mixing

Splashing at low volumes, which can damage milk quality, is prevented thanks to automatically controlled two-speed agitation.

#### T Cleaning Sprayer

The cleaning of the tank is a key aspect of the cooling ensuring top quality milk, over and over again.

To get to all the corners and complete the entire inner surface, DeLaval has integrated the cleaning nozzle in the rotating blades, ensuring a complete and thorough cleaning of the inside of the tank.



Tank size	Max storage capacity (Ltr)	A	B	C	Net weight in kg
11000	11550	2390	2285	2790	1700
15000	15750	3035	3230	3435	2000
20000	21000	3825	4020	4225	2250
25000	26250	4620	4815	5020	2500
30000	31500	5415	5610	5815	2750
35000	36750	6210	6405	6610	3000
40000	42000	7005	7200	7405	3250

## DeLaval cooling tank DXCE and DXCEM

Find the correct size according to your capacity requirements

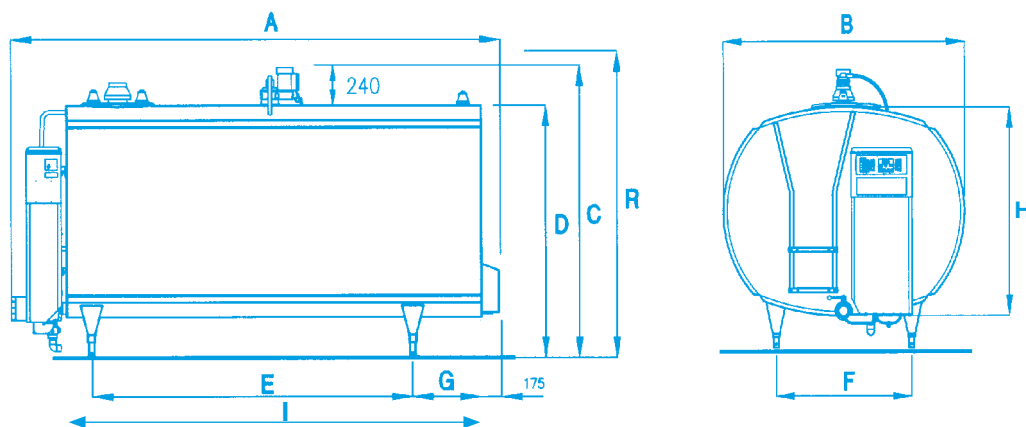

Dimensions in mm; Capacity in litres

DXCE/M

Tank size	Milk tank model	Total length	Total width	Min. height	Height tank +feet	Feet dist. length	Feet dist. width	Dist. feet to rear end	Height tank body	Tank length	Height (tank at 3%)	K	L	Net weight in kg	P
		A	B	C	D	E	F	G	H	I	R				
1150	DXCE	1960	1400	1540	1351	1015	830	200	1080	1400	1653	1	4	340	1
1300	DXCE	2125	1400	1536	1351	1080	830	250	1080	1565	653	1	4	360	1
1600	DXCE	2455	1400	1535	1351	1410	830	250	1080	1895	653	1	4	390	1
2000	DXCE	2895	1400	1535	1351	1850	830	250	1080	2335	653	1	4	425	1
2500	DXCE	3445	1400	1536	1351	2400	830	250	1080	2885	653	1	4	470	1
3000	DXCE	2440	1800	1889	1704	1290	1070	350	1480	1880	2014	2	4	500	1
3500	DXCE	2760	1800	1889	1704	1590	1070	350	1480	2200	2034	2	4	550	1
4000	DXCE	3050	1800	1889	1704	1890	1070	350	1480	2490	2003	2	4	600	1
4500	DXCE	3350	1800	1889	1704	2190	1070	350	1480	2790	2003	2	4	650	1
5000	DXCE	3115	2000	2002	1824	1870	1035	500	1539	2555	2178	2	4	750	1
6000	DXCE	3600	2000	2002	1824	2350	1035	500	1539	3040	2178	2	4	850	1
6750	DXCE	3910	2000	2000	1813	2522	1035	491	1539	3350	2178	2	4	890	1
7500	DXCE	4230	2000	2023	1814	1650	1035	200	1539	3670	2178	2	6	930	1
8000	DXCE	4560	2000	2052	1820	1810	1035	200	1539	4000	2178	2	6	1080	1
8600	DXCE	4165	2150	2214	2045	1500	1300	350	1748	3605	2400	4	6	1330	1
9700	DXCE	4565	2150	2234	2096	1700	1300	350	1748	4005	2400	4	6	1170	1
11000	DXCE	5115	2150	2330	2075	1315	1300	350	1748	4555	2400	4	6	1250	1
11002	DXCE	5115	2015	2330	2075	1315	1300	350	1748	4555	2400	4	6	1250	2
12001	DXCEM	4753	2270	2583	2075	1520	1300	482	1748	4000	2434	4	6	1550	1
12002	DXCE	5560	2015	2330	2075	1470	1300	250	1748	5000	2400	4	8	1420	2
14000	DXCEM	5413	2270	2631	2353	1850	1300	482	2027	4660	2455	4	6	1750	2
16000	DXCEM	6053	2270	2642	2391	2170	1300	482	2027	5300	2473	4	6	2000	2
16001	DXCEM	4752	2522	2980	2706	1520	1400	482	2400	4000	2809	4	6	2000	2
18000	DXCEM	6692	2270	2671	2392	1660	1300	482	2027	5950	2489	4	8	2300	2
20000	DXCEM	5751	2522	2997	2950	2020	1400	482	2400	5300	2861	4	6	2550	2
24000	DXCEM	6752	2522	3016	2950	1680	1400	482	2400	6000	2868	4	8	2800	2
28000	DXCEM	7752	2522	3040	2892	2010	1400	482	2400	7000	2900	4	8	3110	2
32000	DXCEM	8751	2522	3071	3035	2345	1400	482	2400	8000	2926	4	8	3300	2

K = Number of evaporators    L = Legs on tank    P = Number of agitators